

## Ambient Light Sensor – DIP 3mm T-1 ALS-PDIC204-6C/H88/L378/TR1-4

### Features

- Close responsively to the human eye spectrum
- Light to Current, analog output
- Good output linearity across wide illumination range
- Low sensitivity variation across various light sources
- Operation temperature performance, -40°C to 85°C
- Wide supply voltage range, 1.8V to 5.5V
- Size: 3mm Lamp (Curved lens)
- RoHS compliant and Pb free package
- Compliance with EU REACH

### Description

The ALS-PDIC204-6C/H88/L378/TR1-4 is an ambient light sensor, which incorporates a photodiode and a current amplifier IC in DIP package. EVERLIGHT ALS series products are a good effective solution to the power saving of display backlighting of mobile appliances, such as the mobile phones, NB and PDAs. Due to the high rejection ratio of infrared radiation, the spectral response of the ambient light sensor is close to human eyes.

### Applications

- Detection of ambient light to control display backlighting
  - Mobile devices – Mobile phones, PDAs
  - Computing device – TFT LCD monitor for Notebook computer
  - Consumer device – TFT LCD TV, Video camera, Digital camera, Toys
- Automatic residential and commercial management
- Automatic contrast enhancement for electronic signboard
- Ambient light monitoring device for daylight and artificial light
  - Street light, CCD/CCTV

### Package Dimensions

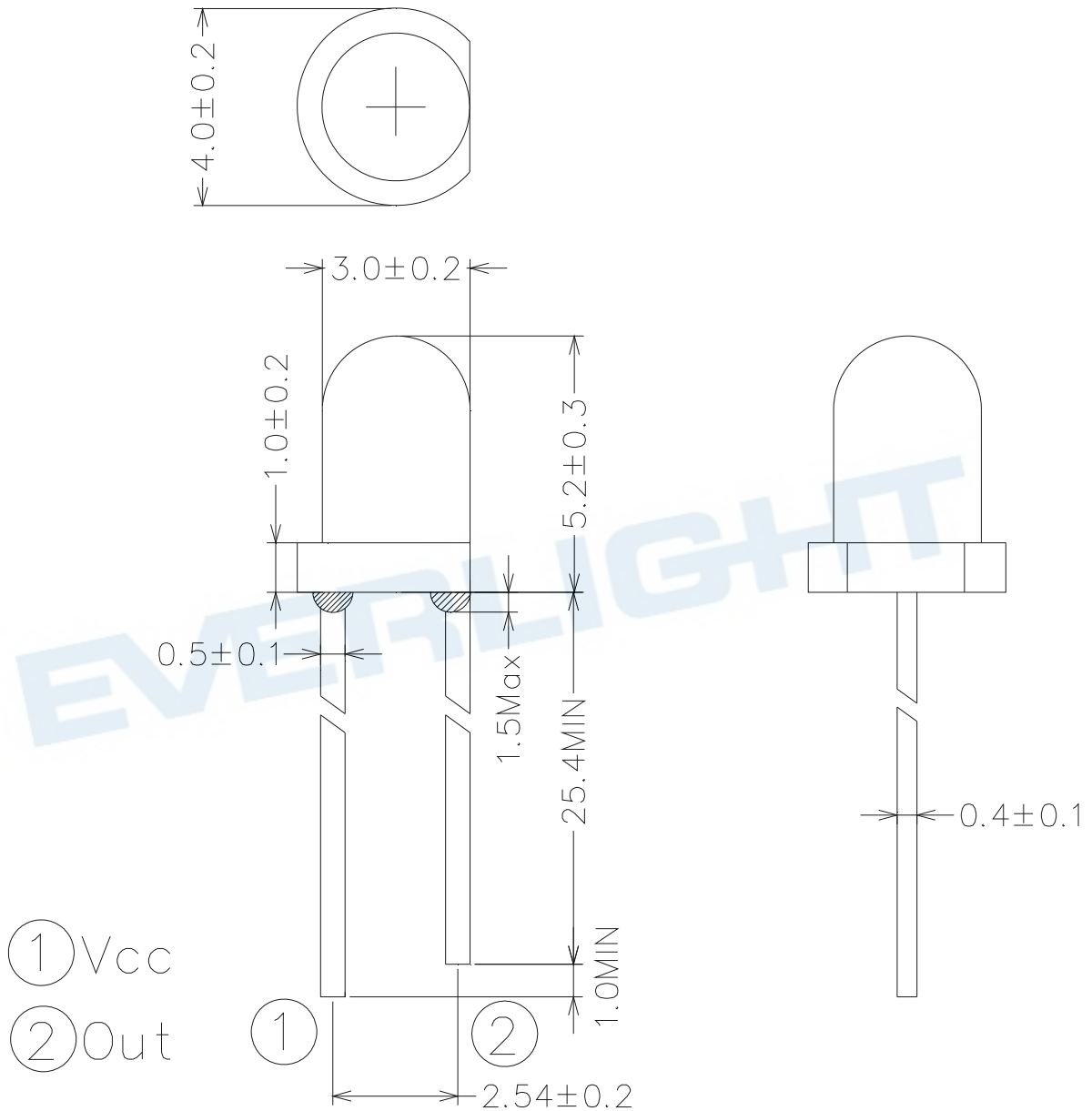

**Notes:** 1.All dimensions are in millimeters  
2.Tolerances unless dimensions  $\pm 0.25$ mm

### Absolute Maximum Ratings

| Parameter                   | Symbol    | Rating     | Unit |
|-----------------------------|-----------|------------|------|
| Supply Voltage              | $V_{CC}$  | -0.7 ~ 6.5 | V    |
| Operating Temperature Range | $T_{opr}$ | -40 ~ +80  | °C   |
| Storage Temperature Range   | $T_{stg}$ | -40 ~ +100 | °C   |
| Soldering Temperature Range | $T_{sol}$ | 260        | °C   |

### Recommended Operating Conditions

| Parameter             | Symbol    | Min. | Max. | Unit |
|-----------------------|-----------|------|------|------|
| Operating Temperature | $T_{opr}$ | -40  | +80  | °C   |
| Supply Voltage        | $V_{CC}$  | 1.8  | 5.5  | V    |

EVERLIGHT

**Electrical and Optical Characteristics (T<sub>a</sub>=25°C)**

| Parameter                    | Symbol           | MIN | TYP  | MAX. | Unit | Test Condition   |
|------------------------------|------------------|-----|------|------|------|--|
| Dark Current                 | I <sub>D</sub>   | 0.1 | --   | 60   | nA   | V <sub>CC</sub> =5V, E <sub>v</sub> = 0Lux             |
| Light Current                | I <sub>PH1</sub> | 5   | --   | 30   | uA   | V <sub>CC</sub> =5V, E <sub>v</sub> = 10 Lux [Note1]   |
|                              | I <sub>PH2</sub> | 50  | --   | 300  | uA   | V <sub>CC</sub> =5V, E <sub>v</sub> = 100 Lux [Note1]  |
|                              | I <sub>PH3</sub> | 500 | --   | 3000 | uA   | V <sub>CC</sub> =5V, E <sub>v</sub> = 1000 Lux [Note1] |
| Peak Sensitivity Wavelength  | λ <sub>p</sub>   | --- | 540  | ---  | nm   | ---  |
| Sensitivity Wavelength Range | λ                | 390 | ---  | 700  | nm   | ---  |
| Rise time                    | t <sub>r</sub>   | --- | 0.36 | ---  | ms   | V <sub>CC</sub> =3V<br>R <sub>L</sub> = 27KΩ           |
| Fall time                    | t <sub>f</sub>   | --- | 1.13 | ---  | ms   |  |

**Note:**

1. White Fluorescent light (Color Temperature = 6500K) is used as light source. However, White LED is substituted in mass production.

Typical Electro-Optical Characteristics Curves

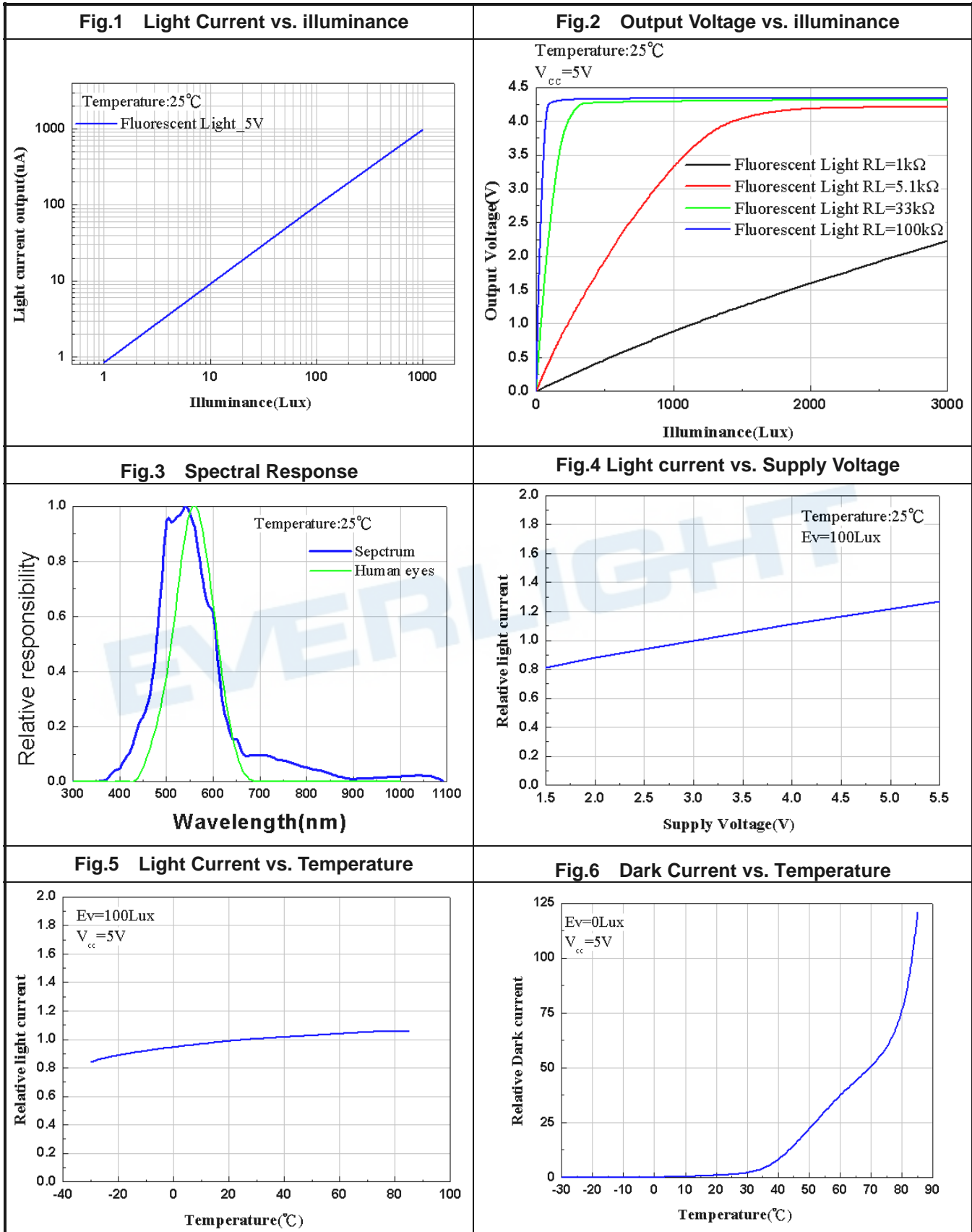

## Converting Photocurrent to Voltage

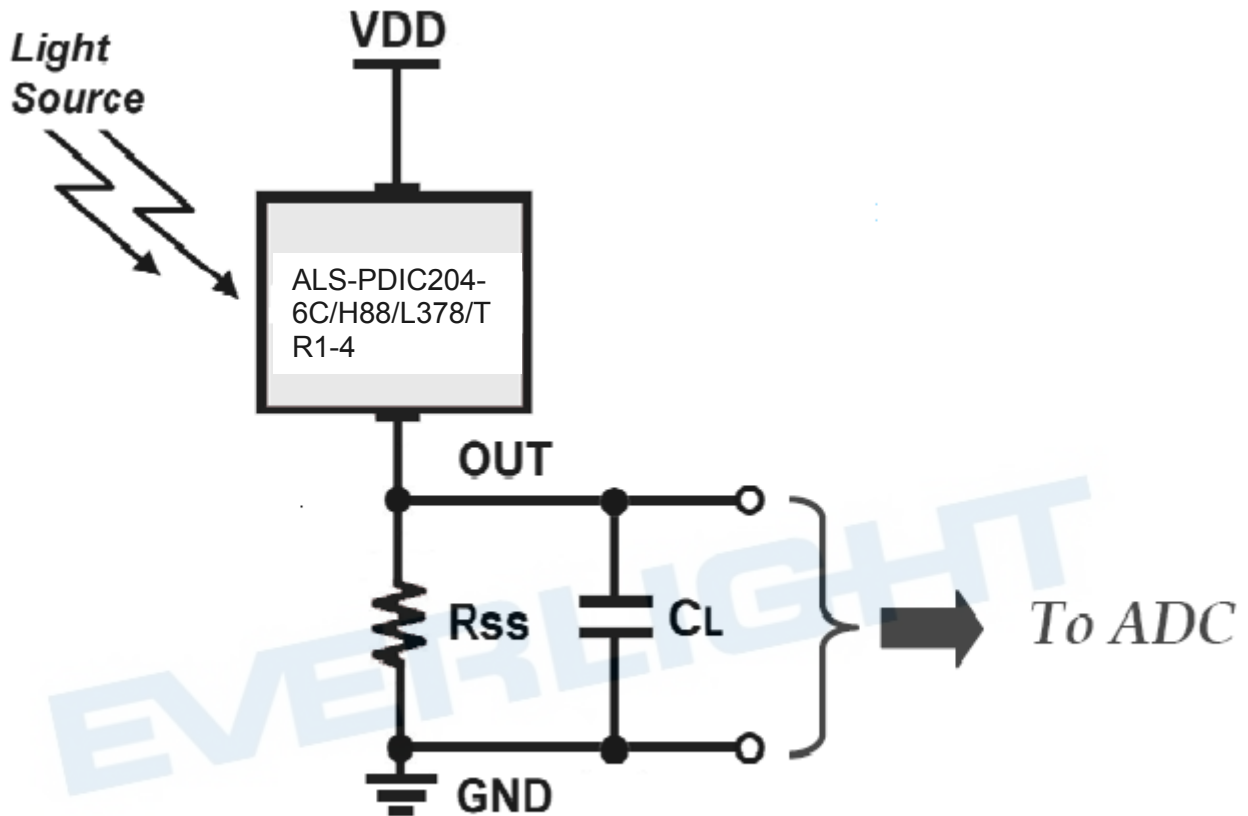

### Note:

1. The output voltage ( $V_{out}$ ) is the product of photocurrent ( $I_{PH}$ ) and loading resistor ( $R_L$ )
2. A right loading resistor shall be chosen to meet the requirement of maximum ambient light, and output saturation voltage:

$$V_{out(max.)} = I_{out(max.)} \times R_L \leq V_{out(saturation)} = V_{CC} - 0.7V$$

## Taping Dimensions

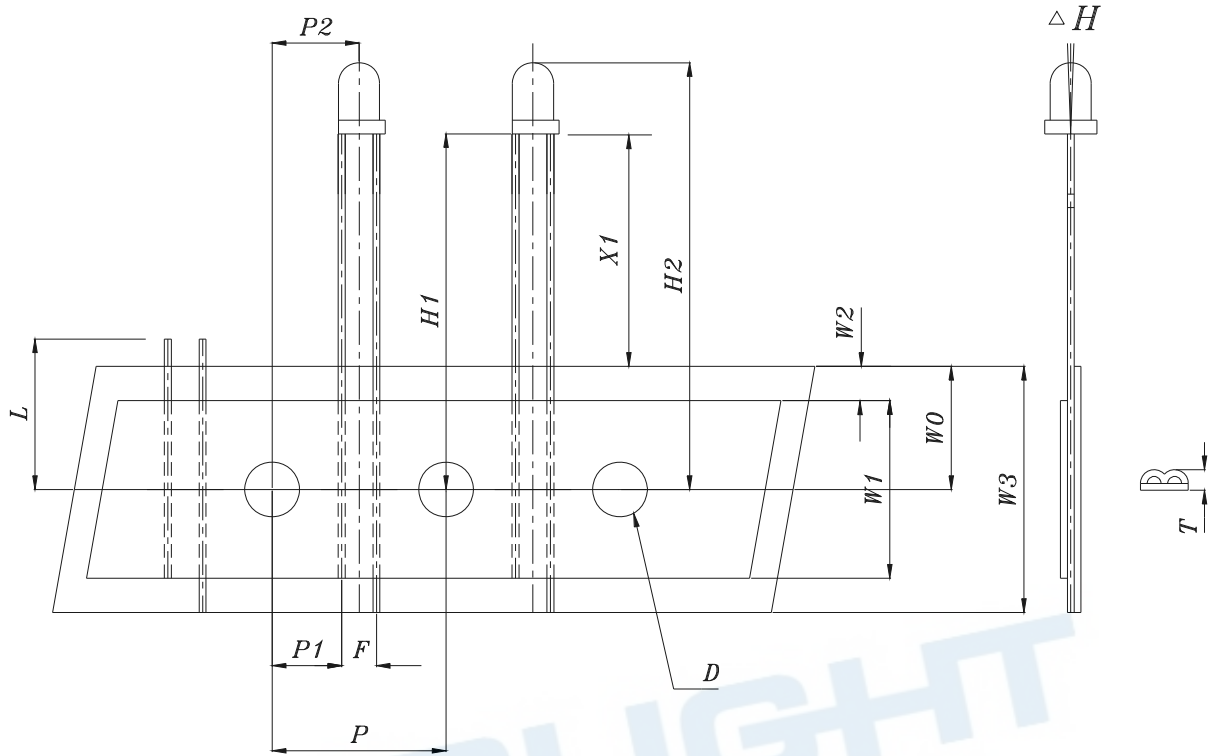

## Taping Sizes

| Symbol Item                           | Symbol | Specifications |       |           |
|---------------------------------------|--------|----------------|-------|-----------|
|                                       |        | Avg            |       | Tolerance |
|                                       |        | mm             | Inch  | mm        |
| Tape Feed Hold Diameter               | D      | 4.0            | 0.157 | ±0.2      |
| Component Lead Pitch                  | F      | 2.54           | 0.1   | +0.8/-0.2 |
| Front-To-Rear Deflection              | ΔH     | 0°             | 0     | ±5°       |
| Feed Hole To Button Of Component      | H1     | 22.4           | 0.882 | ±1.0      |
| Feed Hole To Overall Component Height | H2     | 27.6           | 1.087 | ±1.0      |
| Lead Length After Component Height    | L      | 11.0           | 0.433 | Max       |
| Feed Hold Pitch                       | P      | 12.7           | 0.500 | ±0.3      |
| Lead Location                         | P1     | 5.08           | 0.200 | ±0.7      |
| Center Of Component Location          | P2     | 6.35           | 0.250 | ±1.2      |
| Overall Taped Package Thickness       | T      | 1.42           | 0.056 | Max       |
| Feed Hold Location                    | W0     | 9.0            | 0.354 | ±0.5      |
| Adhesive Tape Width                   | W1     | 13.0           | 0.512 | ±0.5      |
| Adhesive Tape Position                | W2     | 2.0            | 0.079 | Max       |
| Tape Width                            | W3     | 18.0           | 0.709 | ±0.75     |

## Packing Quantity Specification

- 1.1000PCS/1Bag , 5Bags/1Box
- 2.10Boxes/1Carton

## Label Format



- CPN: Customer's Production Number
- P/N : Production Number
- QTY: Packing Quantity
- CAT: Ranks
- HUE: Peak Wavelength
- REF: Reference
- LOT No: Lot Number

## Note

1. Above specification may be changed without notice. EVERLIGHT will reserve authority on material change for above specification.
2. When using this product, please observe the absolute maximum ratings and the instructions for using outlined in these specification sheets. EVERLIGHT assumes no responsibility for any damage resulting from use of the product which does not comply with the absolute maximum ratings and instructions included in these specification sheets.
3. These specification sheets include materials protected under copyright of EVERLIGHT Corporation. Please don't reproduce or cause anyone to reproduce them without EVERLIGHT's consent.